

SRG3123

Combined types 1&2 Lightning & Surge protector with signalling contact for three phase industrial & commercial applications

SRG3123 is a 3P+N lightning and surge arrester designed for use in TN-C-S / TN-S / TT network systems, for installation at the origin of the installation. It is designed for universal application, for the protection of electrical appliances against impulse surge effects when connected to LV supply systems.

The device is recommended for use in the lightning protection zones concept at the boundaries of LPZ 0-1 (according to IEC / EN62305), where it provides the equi-potential bonding and discharge of both the lightning current and the switching surge, which are generated in power supply systems entering the building.

The product comprises 3 metal oxide varistors, combined with a gas discharge tube. A volt free changeover contact is also provided for remote signalling of the device status.

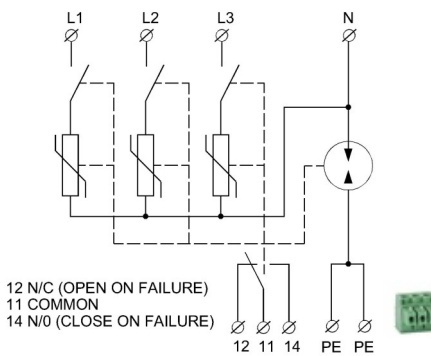

12 N/C (OPEN ON FAILURE)
11 COMMON
14 N/O (CLOSE ON FAILURE)
12 11 14 PE PE

The device must be installed by a qualified electrician in accordance with the latest edition of the IET wiring regulations for electrical installations BS7671: 2018 sections 443 & 534.

Installation

The surge protector must be installed at the very origin of the installation, as close to the electrical intake as possible. The device should be installed ahead of and in parallel to the main distribution board.

Regulation 534.4.8 of BS7671: 2018 stipulates that consideration must be given to the total wiring length of conductors between connection points of the SPD assembly, which should preferably not exceed 0.5 metre, and in no case exceed 1.0 metre (total length). This measurement is made between the live bus bar and the earth terminal, incorporating the connection from the live bus bar to the fuse (A), the fuse to the SPD (B), and the SPD to the earth terminal (C). See diagram

The reason for the restriction in length is to minimise any voltage drop on the connecting cables, which can have a direct effect on the voltage protection level offered by the SPD.

To achieve this requires that connecting cables must be kept as short and as directly routed as possible.

Important:

When conducting insulation resistance tests on the installation, remove either the plug in cartridges, or the earth cable to the device.

Alternatively conduct tests at reduced voltage (250VDC max). Failure to do so will give incorrect readings (due to the SPD starting to conduct as the maximum continuous operating voltage is exceeded), and may cause irreparable damage to the device.

Technical Data	
Reference standard	EN61643-11 IEC61643-11
Test class according to EN61643-11 & IEC61643-11	Type 1&2
Protection Mode(s)	Common/Differential
Network 3ph+N (Un)	400Vac
Max continuous operating voltage (Uc)	280V ac
Nominal discharge current (In) (8/20µS)	20kA (L/N) 80kA (N/PE)
Max. discharge current (Imax)(8/20µS)	50kA (L/N)
Lightning impulse current (Iimp) (10/350µS) by pole	12.5kA (L/N) 50kA (N/PE)
Total lightning current (I total) (Max total withstand 10/350µS)	50kA
Voltage protection level (at In) (Up)	1.3kV (L/N) 1.5kV (N/PE)
Temporary overvoltage (TOV) (UT)	335V/5S (L/N) 1200V/0.2S (N/PE)
Follow Current (If)	None
Maximum rated backup fuse (Fmax)	160A gL/gG
Short circuit withstand capability (Iscrr) at max back up fuse 160A gL/gG	25kA rms
Min-Max conductor size	6-35mm ² L/N 16-35 mm ² PE
Terminal tightening torque	2.0—2.5Nm
Mounting	35mm din rail
Operating temperature range	-40° C to +85° C
Ingress protection rating	IP20
Weight	490g
Dimension	4x 18mm module

Failure indicator flag		Volt free signalling contact
Black	Healthy (ok)	11-12 closed / 11-14 open
Red	Failure (replace)	11-14 closed / 11-12 open

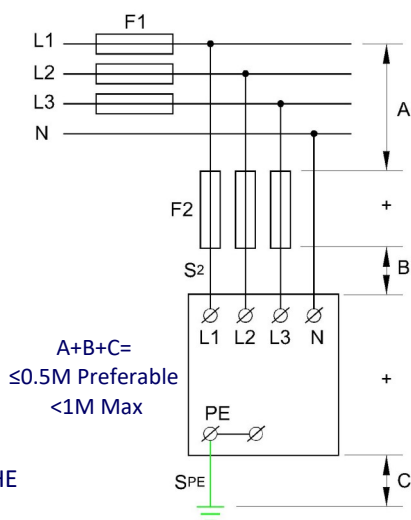

Signalling contact 11-12-14 (Max 1mm ²)	
AC:	250V / 0.5A
DC:	30V/ 3A max

Minimum Conductor Size	
S ₂	6mm ²
S _{PE}	16mm ²

Maximum Back Up Fuse	
F1 > Fmax	F2 = Fmax
F1 ≤ Fmax	F2 ≤ F1 or No F2



THIS GUIDE MUST BE LEFT WITH THE UNIT FOR FUTURE REFERENCE