

SRG1V1G

Type 2 Surge protector with signalling contact for single phase industrial & commercial applications

SRG3V1G is a 1P+N surge arrester designed for use in TN-C-S / TN-S / TT network systems, for installation within subsidiary distribution boards or control boxes. It is designed for universal application, for the protection of electrical appliances against impulse surge effects when connected to LV supply systems. The device is also recommended for use in the lightning protection zones concept at the boundaries of LPZ 1-2 (according to IEC 1312-1 & EN62305)
 The product comprises 1 metal oxide varistor combined with a gas discharge tube. A volt free changeover contact is also provided for remote signalling of the device status.

Technical Data	
Reference standard	BS EN61643-11 IEC 61643-11
Test class according to EN61643-11 & IEC61643-11	Type 2
Protection Mode(s)	Common/Differential
Network 1ph+N (Un)	230V ac
Max cont. operating phase voltage (Uc)	255V ac
Nominal discharge current (In) (8/20µs)	20kA
Max. discharge current (Imax)(8/20µs)	40kA
Voltage protection level (at In) (Up)	1.25kV L/N 1.5kV N/PE
Temporary overvoltage withstand (TOV) (UT)	335V/5S (L/N) 1200V0.2S (N/PE)
Follow Current (If)	None
Residual current leakage (Ipe)	None
Residual voltage at 5kA (8/20µs) (Up 5kA)	0.9kV
Max backup fuse (Fmax)	125A gL/gG
Short circuit withstand capability (Iscrr) at max back up fuse 125A gL/gG	25kA
Recommended backup MCB	C40A or C50A 1P 10kA
Min-Max conductor size	2-35mm ² L/N 6-35mm ² PE
Terminal tightening torque	2.0-2.5Nm
Mounting	35mm din rail
Operating temperature range	-40°C to +85°C
Ingress protection rating	IP20
Weight	175g
Dimension	2x 18mm module

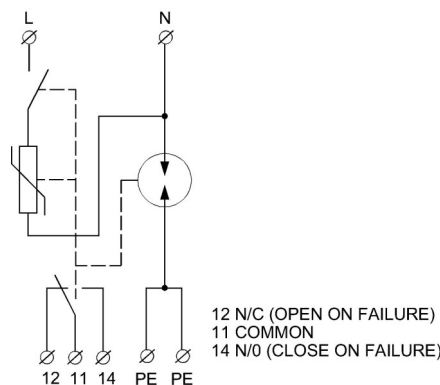

The device must be installed by a qualified electrician in accordance with the latest edition of the IET wiring regulations for electrical installations BS7671

Important:

When conducting insulation resistance tests on the installation, remove either the plug in cartridge, or the earth cable to the device. Alternatively conduct tests at reduced voltage (250VDC max)
 Failure to do so may cause irreparable damage to the surge arrester.

Installation in Lewden TPN distribution boards (converted for Single Phase operation)

When installing within Lewden 125A TPN distribution boards, the surge arrester must be used in conjunction with a Lewden C40A or C50A 1P 10kA MCB (Part number E10-1C40 / E10-1C50). The MCB should be installed on the outgoing L way located closest to the main switch, and the surge arrester fitted within a close coupled extension box (Lewden part number TPN-EXT19). Cable lengths between the MCB, surge arrester and earth bar must be kept to absolute minimum (<1 metre), using a minimum conductor size as detailed in the table below.

Failure indicator flag		Volt free signalling contact
Black	Healthy (ok)	11-12 closed / 11-14 open
Red	Failure (replace)	11-14 closed / 11-12 open

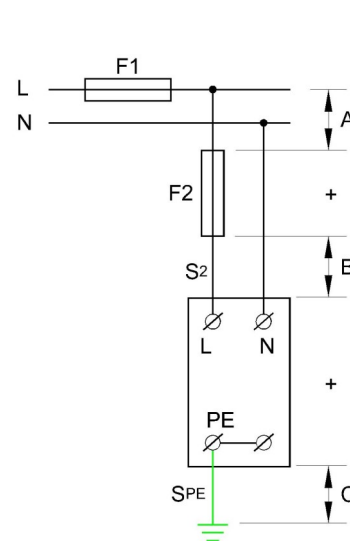

Signalling contact 11-12-14 (Max 1mm ²)	
AC: 250V / 0.5A	
DC: 30V / 3A max	

Minimum Conductor Size	
S ₂	2.5mm ²
S _{PE}	6mm ²

Maximum Back Up Fuse	
F1 > Fmax	F2 = Fmax
F1 ≤ Fmax	F2 ≤ F1 or No F2

A+B+C = ≤0.5M Preferable / <1M Max